



# EMPTMEYER

ZÁVĚSY A MASKOVÁNÍ



PRO VAŠI **BAREVNOU BUDOUCNOST**



- HÁKY A ZÁVĚSY
- EFEKTIVITA ZAVĚŠOVÁNÍ
- MASKOVÁNÍ JAKO SOUČÁST LAKOVÁNÍ
- SKLADOVÁNÍ A DOPRAVA



# VÝBĚR SPRÁVNÉHO HÁKU

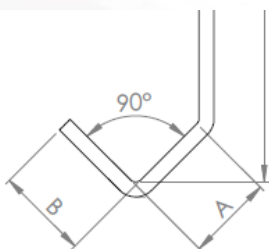

- Hranaté háčky
  - Různé délky ramen
  - Průměr a délka

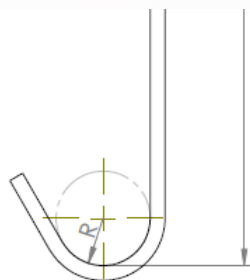

- Kulaté háčky
  - Různé poloměry
  - Průměr a délka

## 121.1 | LAKOVACÍ HÁKY C-TVAR | HRANATÉ

ROVINNÉ

OZNAČENÍ MATERIÁLU  
Ocel S235 JR

Na požádání Vám můžeme dodat lakovací háky z různých materiálů (např. z pružinové oceli, nerezové oceli a VA-pružinové oceli) v individuálních délkách a průměrech drátů (až do 30 mm).

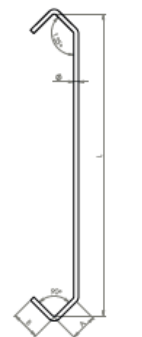

KATALOG. Č.	KUSŮ / BALENÍ	L x Ø V MM	RAMENO A/B V MM
121.100110005000K	10,000	50 x 1,10	20/20
121.100150005000K	5,000	50 x 1,50	20/20
121.100200005000K	4,000	50 x 2,00	20/20
121.100300005000K	3,000	50 x 3,00	20/20
121.100150006000K	5,000	60 x 1,50	20/20
121.100200006000K	4,000	60 x 2,00	20/20
121.100300006000K	2,000	60 x 3,00	20/20
121.100150007500K	4,000	75 x 1,50	20/20
121.100200007500K	4,000	75 x 2,00	20/20
121.100300007500K	2,500	75 x 3,00	20/20
121.100400007500K	1,200	75 x 4,00	20/20
121.100600007500K	500	75 x 6,00	22/22
121.100150010000K	3,000	100 x 1,50	20/20
121.100200010000K	3,000	100 x 2,00	20/20
121.100250010000K	2,000	100 x 2,50	20/20
121.100300010000K	1,500	100 x 3,00	20/20
121.100400010000K	800	100 x 4,00	20/20
121.100500010000K	500	100 x 5,00	22/22
121.100600010000K	500	100 x 6,00	22/22

## LAKOVACÍ HÁČEK



C-TVAR | HRANATÝ  
ARTIKL Č. 121.1  
Strana č. 020



C-TVAR | KULATÝ  
ARTIKL Č. 170.0  
Strana č. 027



S-TVAR | KULATÝ  
ARTIKL Č. 191.0  
Strana č. 032



C-TVAR | HRANATÝ  
ARTIKL Č. 121.0  
Strana č. 025



C-TVAR | KULATÝ  
ARTIKL Č. 170.1  
Strana č. 030



S-TVAR | KULATÝ  
ARTIKL Č. 191.1  
Strana č. 033



# ZATÍŽENÍ HÁKŮ

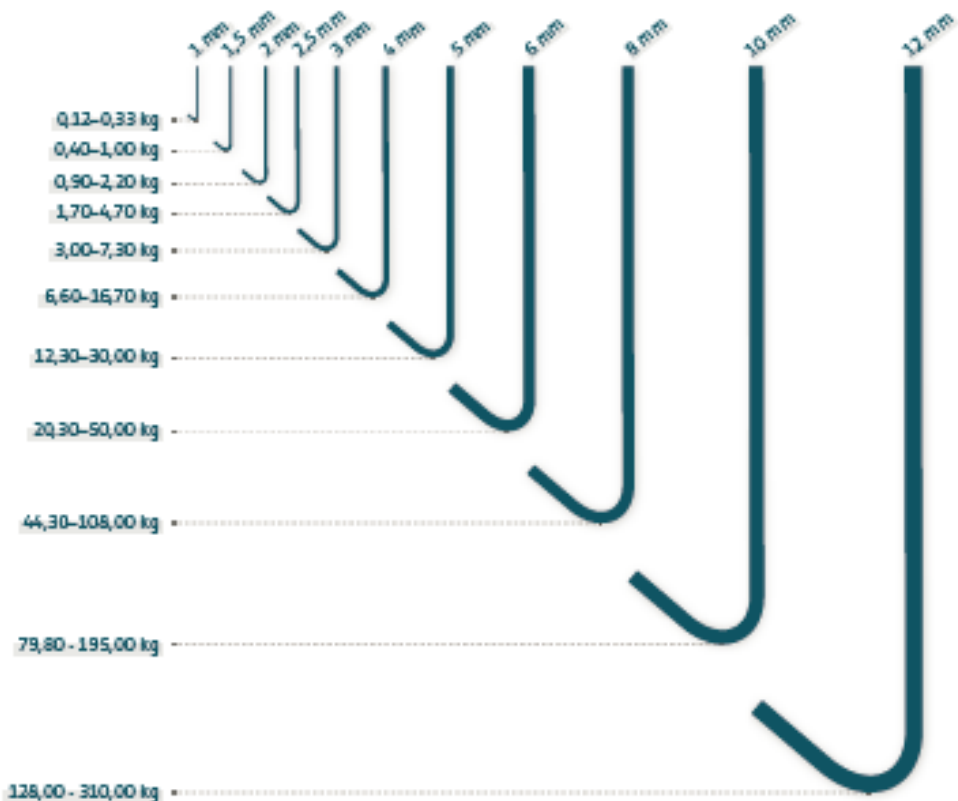

- Tabulka nosnosti háků
- Certifikování nosnosti konkrétního háku

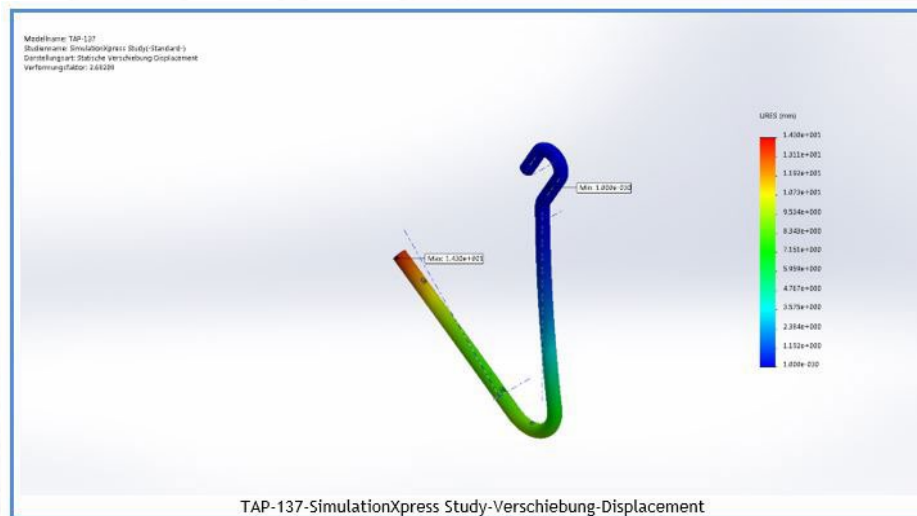

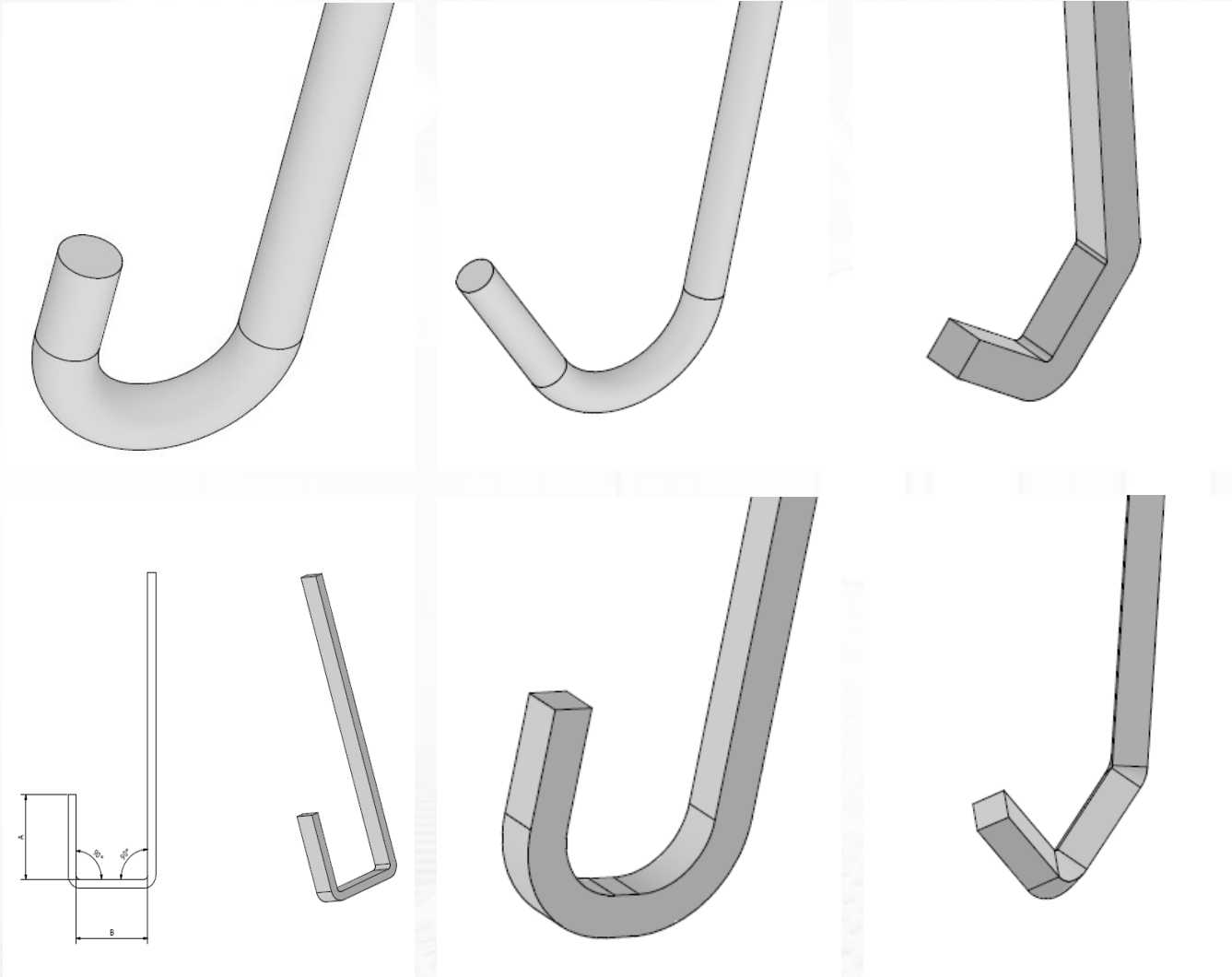

- **Různé materiály**
  - Ocel (S235 JR), hliník, nerez, pružinová ocel
- **Různé tvary a velikosti**
  - Průměr až 30 mm
  - Čtyřhran až 20 mm
  - Plochá ocel



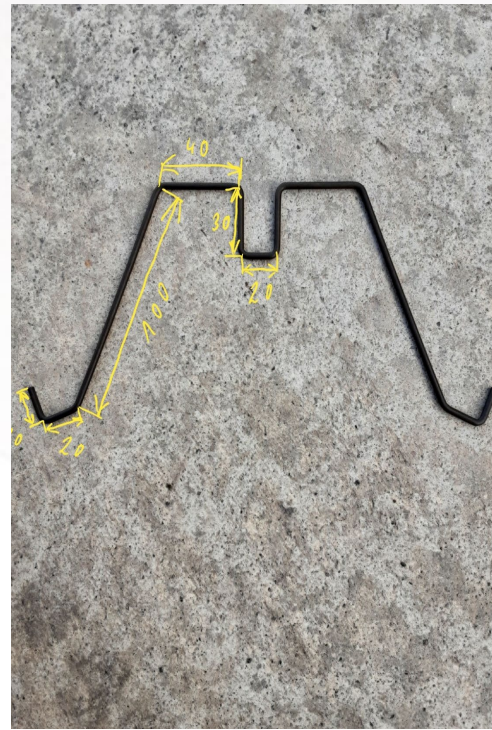
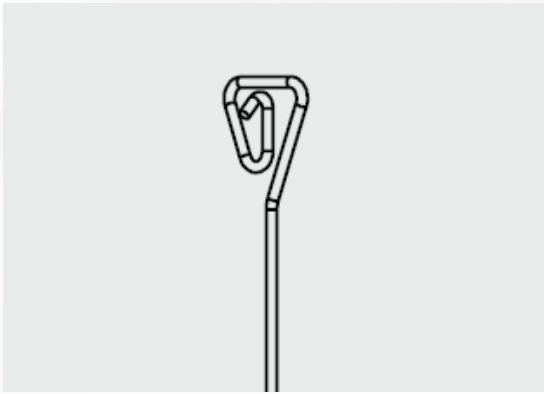

- Zajištění stability
  - pomocí 3D háku
  - pomocí tvarovaného háku
- Výroba podle výkresu
  - Podle vzoru
  - Podle výrobku

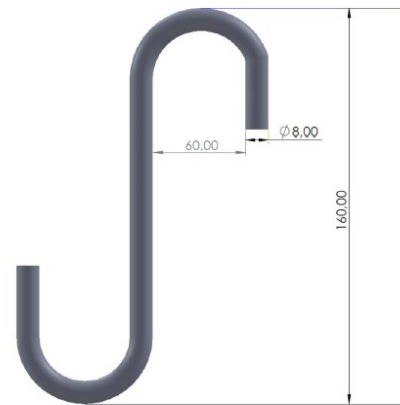
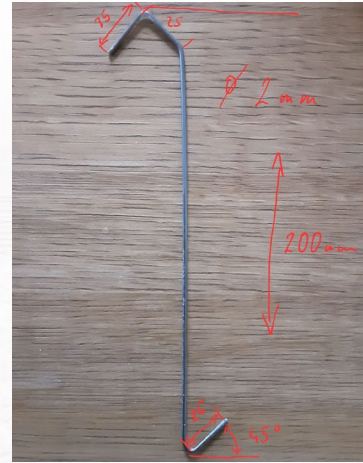
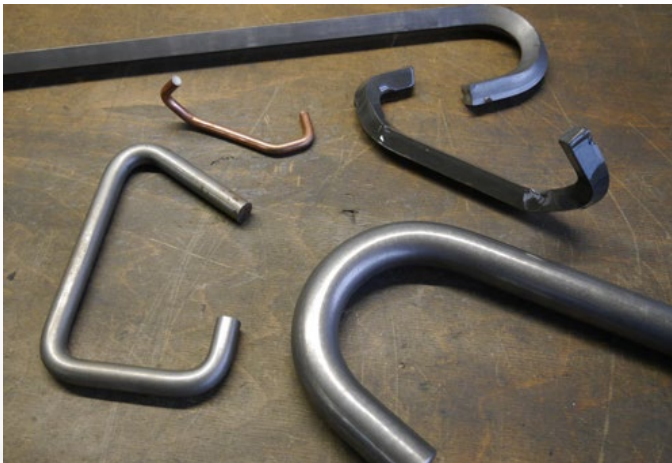



PRO VAŠI **BAREVNOU BUDOUCNOST**



# Odlakovávat?

externě x interně

## Od jakého průměru?

## Při jakém množství?

### C hák kulatý



100 x 1,5 mm	0,33	825 Kč	2500 ks
100 x 2 mm	0,45	1 125 Kč	2500 ks
100 x 2,5 mm	0,90	1 350 Kč	1500 ks
100 x 3 mm	1,20	1 800 Kč	1500 ks
100 x 4 mm	2,45	1 225 Kč	500 ks
100 x 5 mm	4,10	2 050 Kč	500 ks
100 x 6 mm	4,88	2 440 Kč	500 ks
100 x 8 mm	11,00	3 300 Kč	300 ks

### C hák hranatý



100 x 1,5 mm	0,30	900,- Kč	3000 ks
100 x 2 mm	0,44	1320,- Kč	3000 ks
100 x 2,5 mm	0,62	1240,- Kč	2000 ks
100 x 3 mm	0,88	1320,- Kč	1500 ks
100 x 4 mm	1,75	1400,- Kč	800 ks
100 x 5 mm	2,59	1295,- Kč	500 ks
100 x 6 mm	3,29	1645,- Kč	500 ks
100 x 8 mm	6,50	1950,- Kč	300 ks

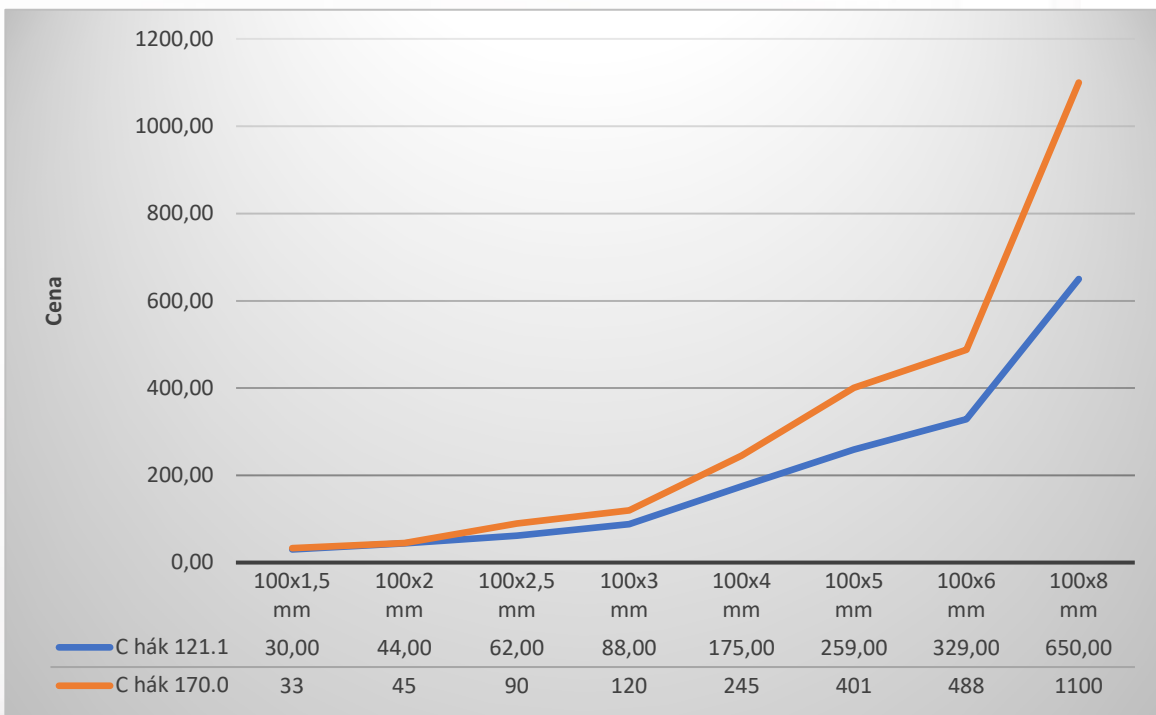



# PRUŽINOVÉ HÁKY A SVORKY

KATALOG. Č.	KUSŮ / BALENÍ	L X Ø V MM	B V MM
251.10	500	200 x 2,00	18
251.20	500	200 x 2,00	28
251.30	250	200 x 3,00	42

KATALOG. Č.	KUSŮ / BALENÍ	L X Ø V MM	B V MM
252.10	500	200 x 2,00	18
252.20	500	200 x 2,00	28
252.30	250	200 x 3,00	42

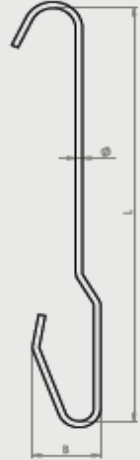

252. LOMENNÉ

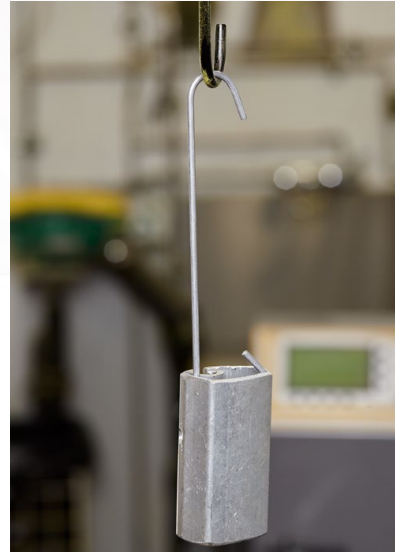

- Snížení otlaků od závěsů
- Zavěšování lehkých předmětů a lišt
- Možnost lakování dílů bez otvorů pro hák

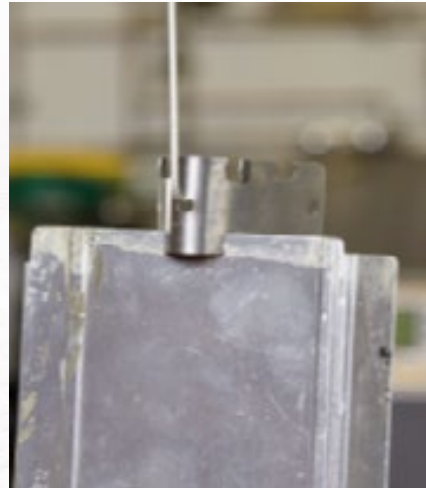
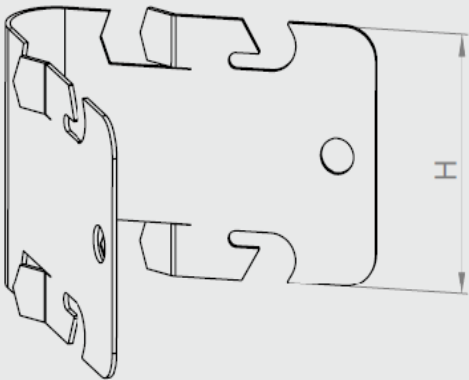

# PRUŽINY A JEJICH MOŽNOSTI

- Pevná pozice výrobku
- Využití lakovacího prostoru
- Možnost přípravy rámců

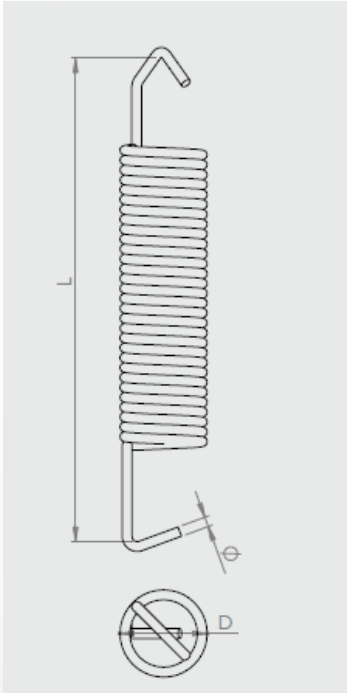



# OTOČNÉ SYSTÉMY

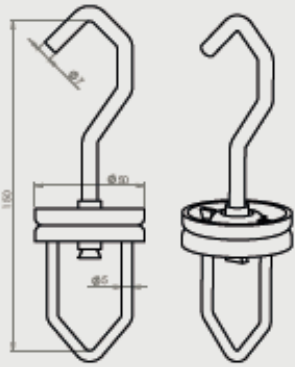

OTOČNÝ SYSTÉM  
DV.01

- Volné otáčení na kuličkovém ložisku
- otevřené provedení
- jednoduchá manipulace
- z pozinkované oceli

OTOČNÝ SYSTÉM  
DV.02

- možnost aretace v celém rozmezí úhlu 90°
- uzavřené provedení
- k namontování natrvalo
- z ušlechtilé oceli

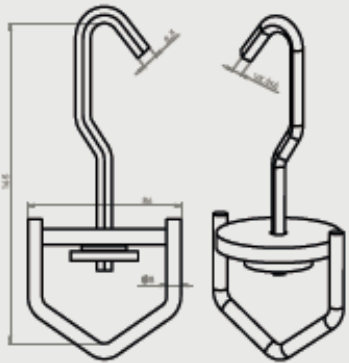
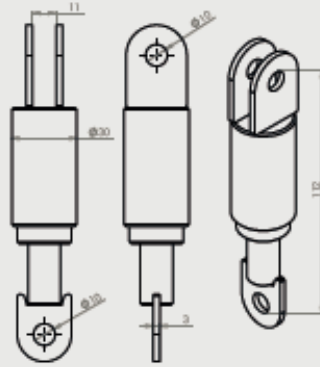

OTOČNÝ SYSTÉM  
DV.03

- volné otáčení
- vylepšené otáčení pomocí mosazného disku
- otevřené provedení
- jednoduchá manipulace
- z oceli

- Možnost aretace
- Ložiskové provedení
- Snížení deformace otvoru pro zavěšení

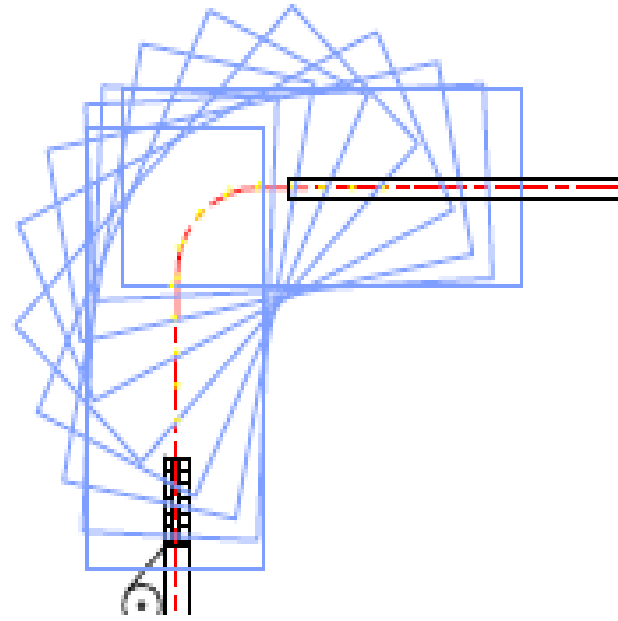

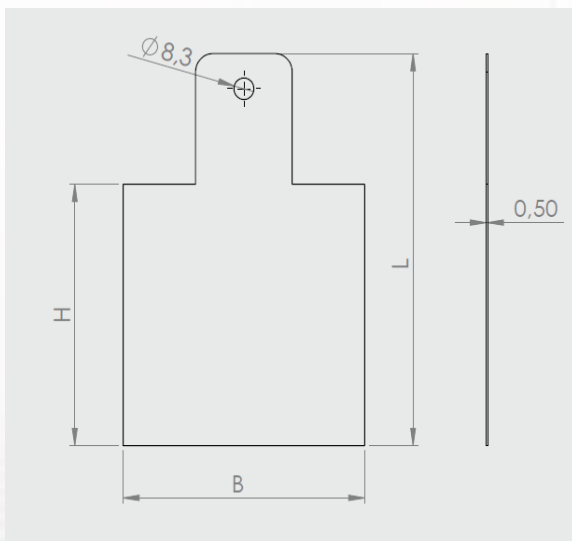
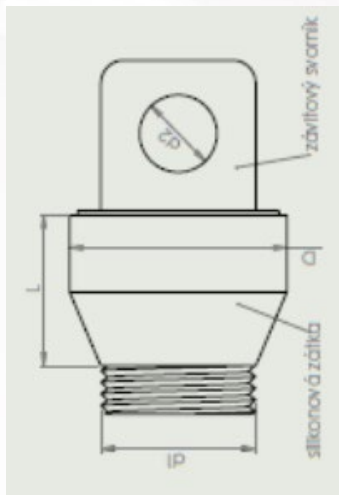

- Závěsná oka 2v1
  - maskování a zavěšení
- Závěsné lepící desky
  - Nosnost až 5 kg



# ZÁVĚSY A ZÁVĚSNÉ SYSTÉMY

## EFEKTIVITA A VYUŽITÍ LAKOVACÍHO PROSTORU

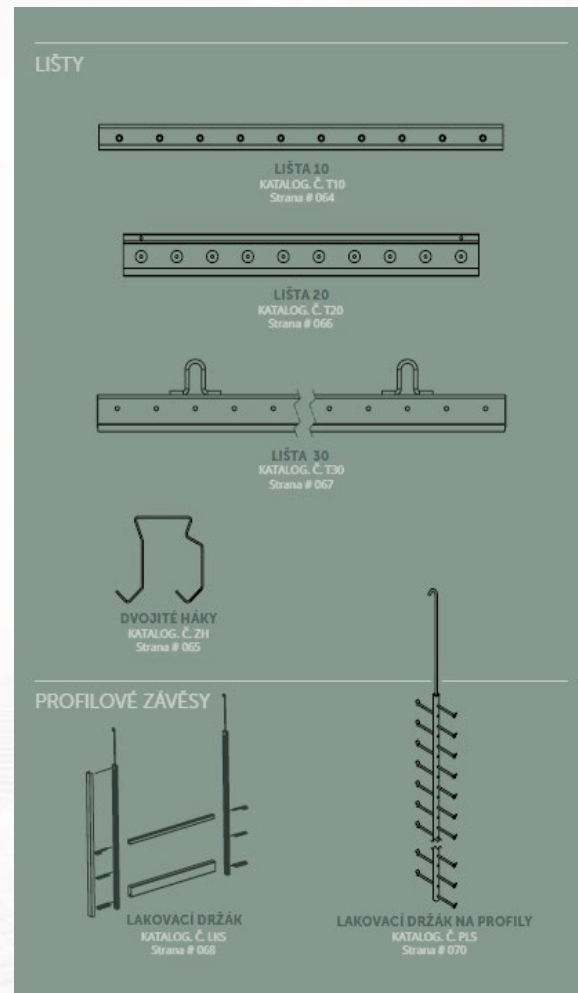
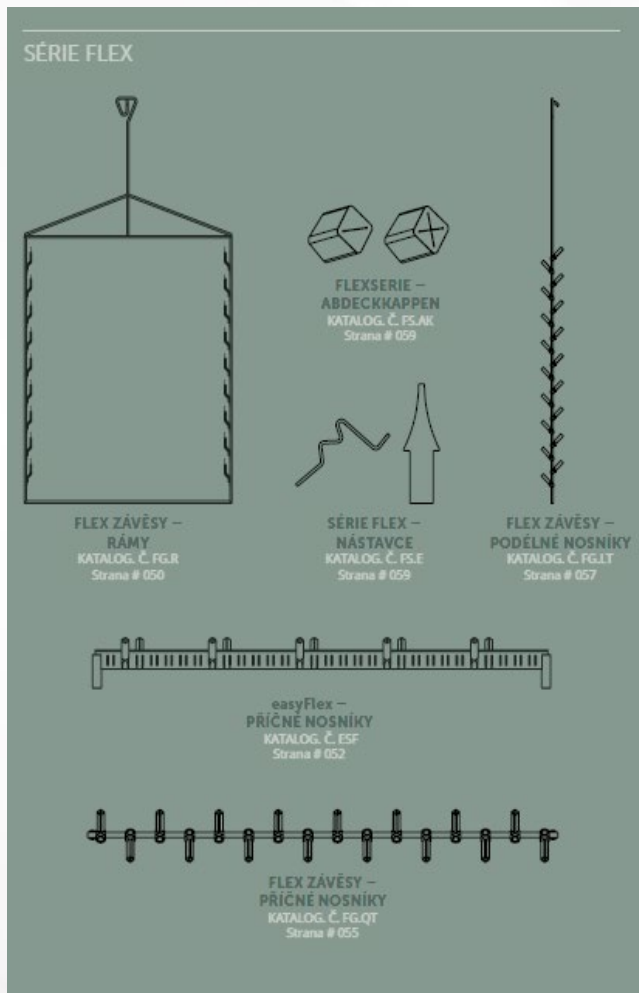

- Série flex
  - rámy, svislé nosníky
- Lišty
- Lakovací držáky



KRYTKA S POMŮCKOU PRO  
SNADNOU MANIPULACI  
KMA.06x25 | Strana 120

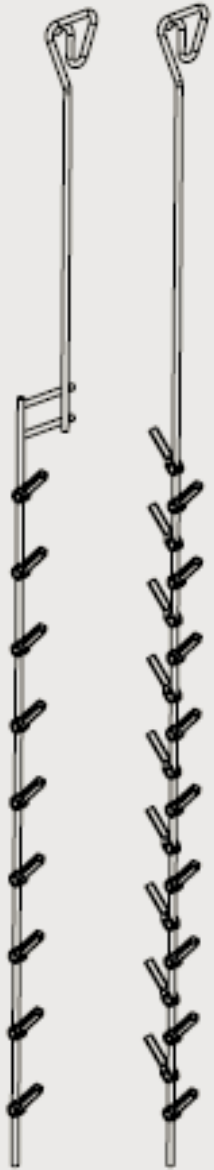

FG.LT FLEX ZAVĚSY –  
PODELNÉ NOSNÍKY

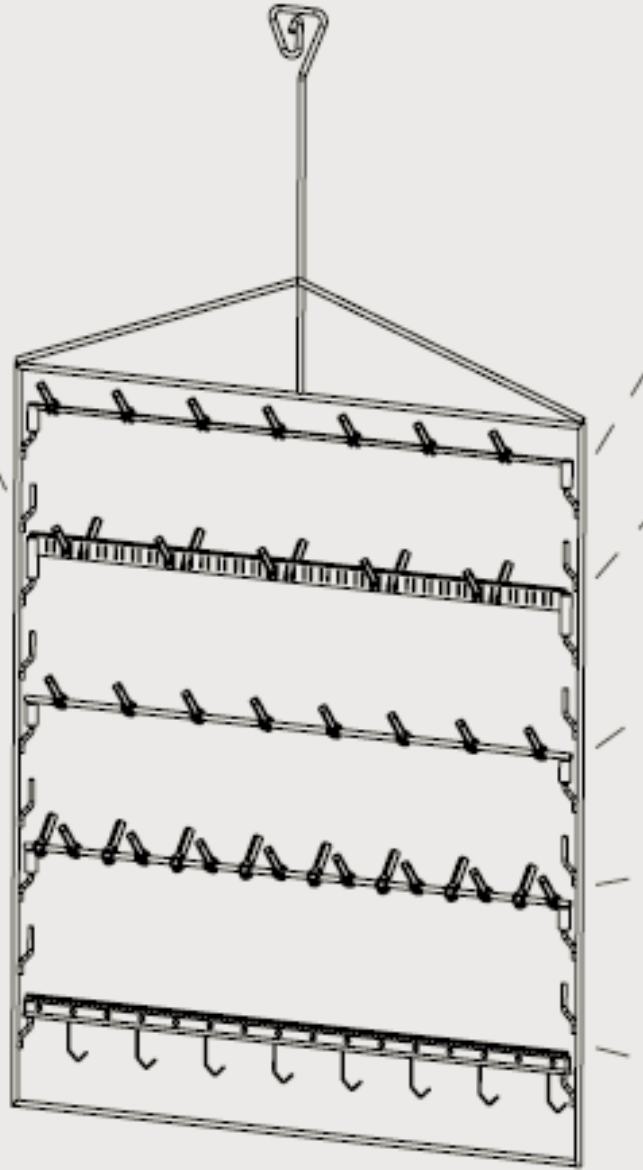

FG.R FLEX ZAVĚSY –  
RÁMY

## SÉRIE FLEX

- Variabilita
- Různé druhy nosníků a nástavců
- Krytky pro zachování kontaktů



### HROTY HROTY OCEL S235 JR - BLANK

KATALOG. Č.	KUSŮ / BALENÍ	L V MM	B V MM	t V MM
FS.E.PSK.16.125	500	50	16	1,25
FS.E.PSK.22.125	500	55	22	1,25
FS.E.PSK.16.200	500	50	16	2,00
FS.E.PSK.22.200	500	55	22	2,00

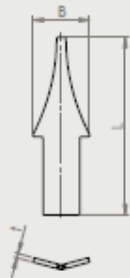

### ČTYŘHRANNÉ HÁKY OCEL S235 JR - BLANK

KATALOG. Č.	KUSŮ / BALENÍ	L V MM	VK V MM
FS.E.VKH.25	1.000	25	3,00 x 3,00
FS.E.VKH.50	1.000	50	3,00 x 3,00
FS.E.VKH.80	1.000	80	3,00 x 3,00



### HROTY DLOUHÉ OCEL S235 JR - BLANK

KATALOG. Č.	KUSŮ / BALENÍ	L V MM
FS.E.PSL.050	200	50
FS.E.PSL.100	200	100
FS.E.PSL.150	200	150

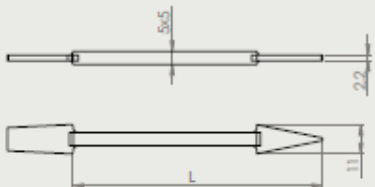

## ■ Příklady nástavců pro sérii flex





- Krytky pro zachování kontaktů



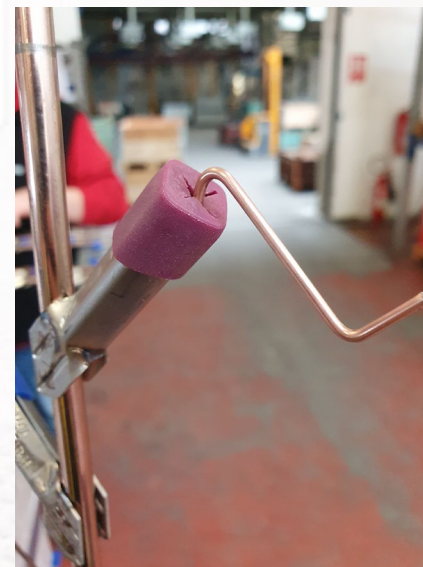

PRO VAŠI **BAREVNOU BUDOUCNOST**





PRO VAŠI **BAREVNOU BUDOUCNOST**



KATALOG. Č.	L V MM	NAVĚŠOVACÍ BODY
-------------	-----------	--------------------

T10.0500	500	10
T10.0600	600	12
T10.0800	800	16
T10.1000	1.000	20
T10.1200	1.200	24
T10.1500	1.500	30
T10.2000	2.000	40

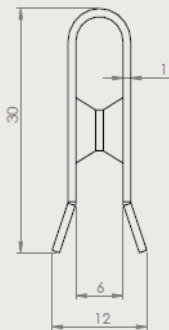

- Lišty T10, T20, T30
- Lišty T10 a T20 - light
- Široká škála použití

KATALOG. Č.	L V MM	NAVĚŠOVACÍ BODY
-------------	-----------	--------------------

T20.0500	500	10
T20.0600	600	12
T20.0800	800	16
T20.1000	1.000	20
T20.1200	1.200	24
T20.1500	1.500	30
T20.2000	2.000	40

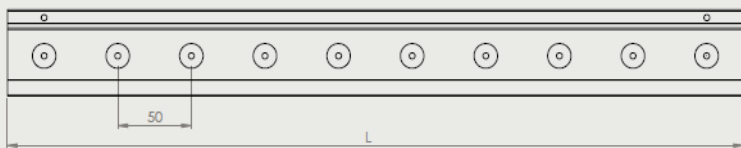
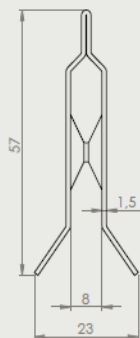

KATALOG. Č.	L V MM	NAVĚŠOVA- CÍ BODY	NAVĚŠOVACÍ OČKA	L1 V MM
-------------	-----------	----------------------	--------------------	------------

T30.2000	2.000	20	2	1.500
T30.3000	3.000	30	3	2.000
T30.4000	4.000	40	3	3.000

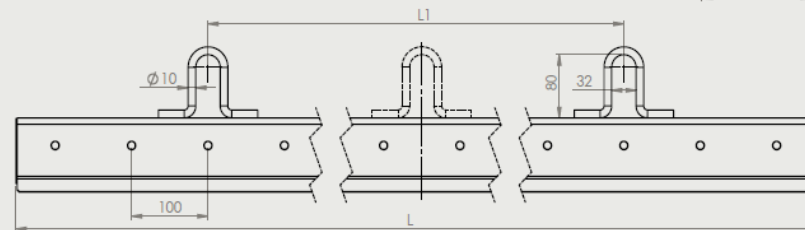
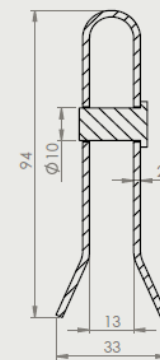

- Varianta light



- Standartní provedení





## ■ LAKOVACÍ DRŽÁK

- Efektivita
- Stabilita
- Různé zasouvací díly
- Krycí plech

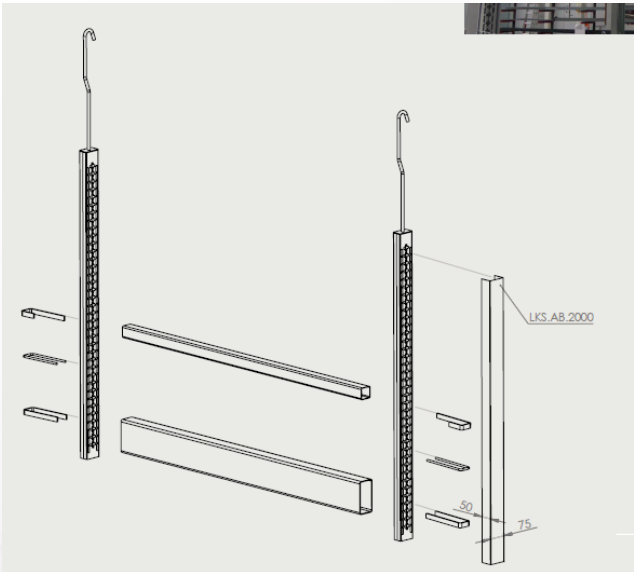

# MASKOVÁNÍ JAKO NEDÍLNÁ SOUČÁST LAKOVACÍHO PROCESU

## MASKOVÁNÍ



### MASKOVACÍ PÁSKA

<b>ZELENÁ</b> KATALOG. Č. AA Strana # 076	<b>MODRÁ</b> KATALOG. Č. AD Strana # 077
<b>CHAMOIS</b> KATALOG. Č. 4331 Strana # 078	<b>FIBERGLAS</b> KATALOG. Č. AF Strana # 079
<b>JANTAROVÁ</b> KATALOG. Č. AG Strana # 080	<b>OBOUSTRANNÁ</b> KATALOG. Č. DK Strana # 081
<b>BĚŽOVÁ</b> KATALOG. Č. AC Strana # 082	<b>SAMOLEPÍCÍ PÁSKA</b> KATALOG. Č. AB Strana # 083
<b>VINYL</b> KATALOG. Č. AV Strana # 084	<b>MASKOVACÍ PAPIR</b> KATALOG. Č. MP Strana # 085
<b>AUTOMATICKÁ ŘEZAČKA</b> KATALOG. Č. 915.05.0 Strana # 086	

### MASKOVACÍ KOLEČKA

<b>ZELENÁ</b> KATALOG. Č. RA Strana # 087	<b>S ŮCHYTEM   ZELENÁ</b> KATALOG. Č. RAA Strana # 088
<b>ŽLUTÁ</b> KATALOG. Č. RC Strana # 089	<b>MAGNETICKÉ</b> KATALOG. Č. MR Strana # 090

### ZÁTKY



**TVAROVANÉ ZÁTKY PRO ZÁVITOVANÉ OTVORY**  
KATALOG. Č. FFG  
Strana # 091



**TVAROVANÉ ZÁTKY PRO ZÁVITOVÉ OTVORY (ŠROUBY SE ZÁPUSTNOU HLAVOU)**  
KATALOG. Č. FFS  
Strana # 092



**TVAROVANÉ ZÁTKY PRO ZÁVITOVÉ OTVORY (ŠROUBY S VÁLCOVOU HLAVOU)**  
KATALOG. Č. PFZ  
Strana # 093



**ZÁTKY KUŽELOVÉ**  
KATALOG. Č. KS  
Strana # 094

### MASKOVACÍ KRYTKY



**MASKOVACÍ KRYTKY S LÍMCEM**  
KATALOG. Č. KAB  
Strana # 113



**MASKOVACÍ A IZOLAČNÍ KRYTKY**  
KATALOG. Č. KA  
Strana # 114



**OBDELNÍKOVÉ KRYTKY**  
KATALOG. Č. RK  
Strana # 117



**KRYTKY PRO MASKOVÁNÍ OS (ROVNE)**  
KATALOG. Č. KAA  
Strana # 118



**MASKOVACÍ KRYTKY**  
KATALOG. Č. VK  
Strana # 119



**MASKOVACÍ KRYTKY S POMŮCKOU PRO SNADNOU MANIPULACI**  
KATALOG. Č. KMA  
Strana # 120



**MASKOVACÍ KRYTKY UZEMŇOVACÍ**  
KATALOG. Č. 903  
Strana # 121



**KLEŠTĚ NA HADICE**  
KATALOG. Č. 912.00.0  
Strana # 126

### MASKOVACÍ HADICE



**MASKOVACÍ HADICE**  
KATALOG. Č. AS  
Strana # 122



**HADICE ŘEZANÉ**  
KATALOG. Č. SCA  
Strana # 123



**STARTUBE**  
KATALOG. Č. SST  
Strana # 124



**MASKOVACÍ PROFIL KULATÝ**  
KATALOG. Č. SC  
Strana # 125



**MASKOVACÍ PROFIL HRANATÝ**  
KATALOG. Č. SCX  
Strana # 126



**KRYCÍ PLECH**  
KATALOG. Č. BL  
Strana # 127

- Pásky
- Výseky
- Silikonové zátky
- Maskovací profily





SKLADEM

TEPELNÁ  
ODOLNOST  
DO 220°C

ODOLNOST  
PČERVENÁI  
ROZTRŽENÍ

66 M/  
ROLI

VZORKY NA  
VYŽÁDÁNÍ

1  
ROLE

SPECIÁLNÍ  
VELIKOSTI NA  
VYŽÁDÁNÍ

KUSY  
ŘEZANÉ  
NA PLOT-  
TERU

TLOUŠŤKA  
0,08 MM

SÍLA  
PŘILNAVOSTI  
8 N/25 MM

## ■ MASKOVACÍ PÁSKY

- polyester
- polyamid





# MASKOVACÍ VÝŘEZY

- Kolečka, čtverce
- Výřezy na míru

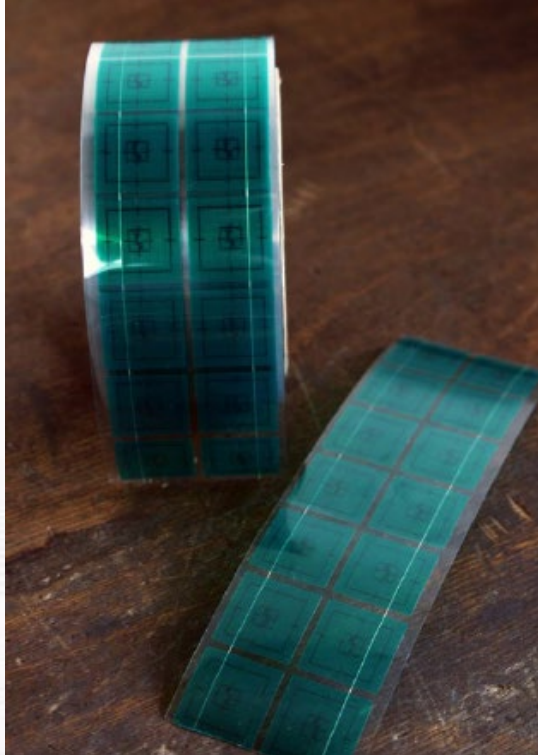

# SILIKONOVÉ ZÁTKY

- Standartní silikon
- Zdravotnický silikon

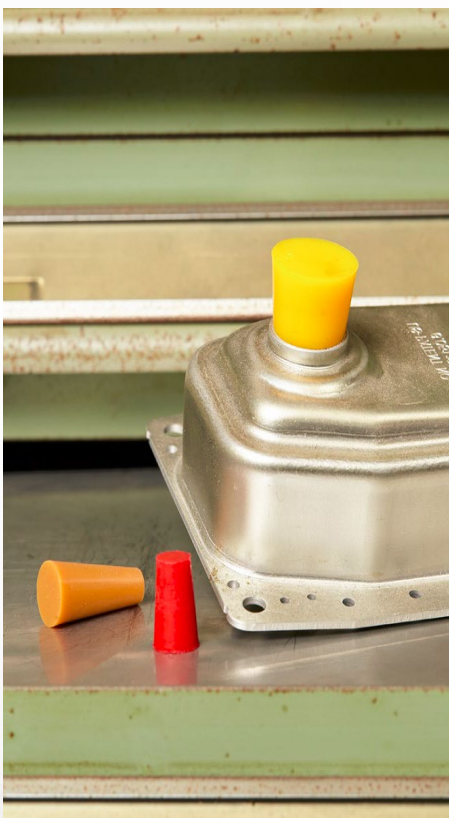

KUSŮ / BALENÍ	Ø d V MM	Ø D V MM	L V MM	ZÁVITY
100	0,80	2,54	16,50	
100	1,60	3,20	16,50	M3
100	1,60	4,75	19,00	
100	2,80	4,70	10,00	



# MASKOVACÍ PROFILY

- Možnost maskování nepravidelných tvarů

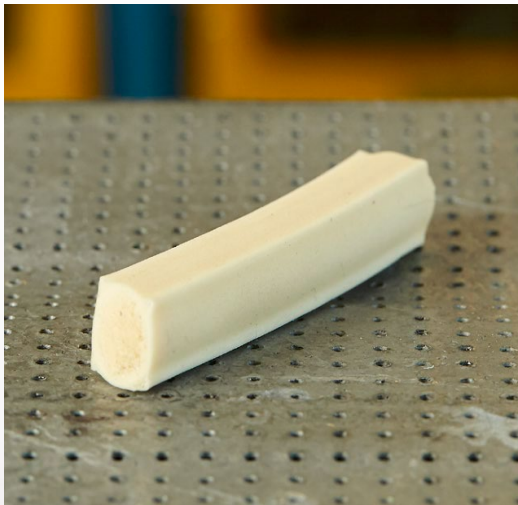

# Skladování a doprava



- Minimální skladová zásoba
- Šířka sortimentu





Ing. Vít Gromeš  
+420 777 717 519  
[gromes@surfin-tech.cz](mailto:gromes@surfin-tech.cz)



[facebook.com/surfintechnology](https://facebook.com/surfintechnology)



[cz.linkedin.com/company/surfin-technology-s.r.o.](https://cz.linkedin.com/company/surfin-technology-s.r.o.)

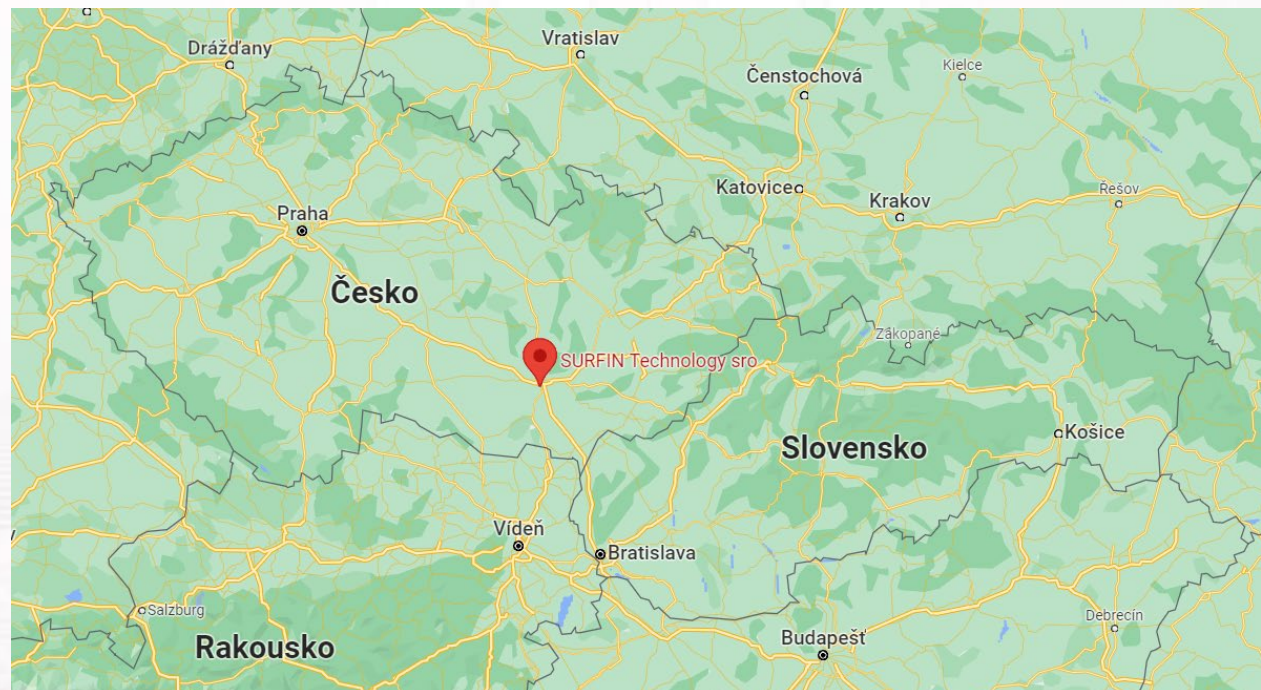

PRO VAŠI **BAREVNOU BUDOUCNOST**

